

(No Model.)

C. A. LOUGEE.

AUTOMATIC TOOL GUIDING DEVICE.

No. 287,838.

Patented Nov. 6, 1883.

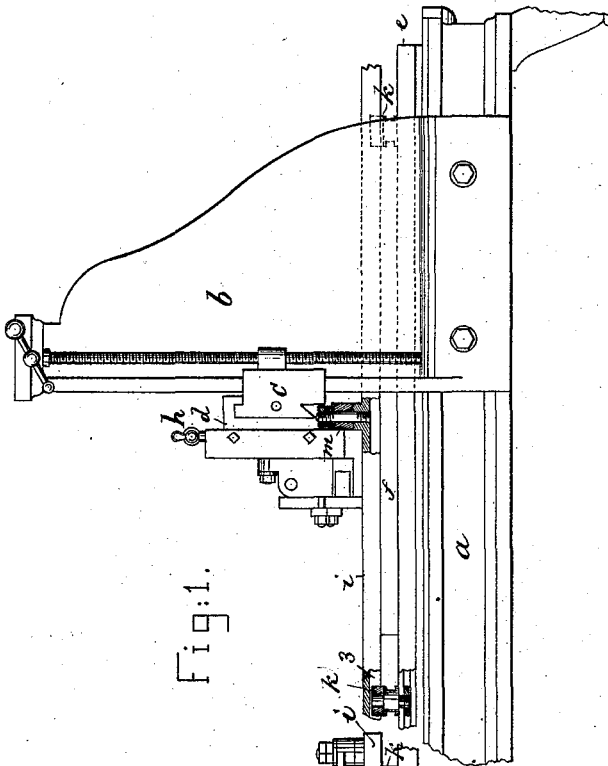

Fig:1.

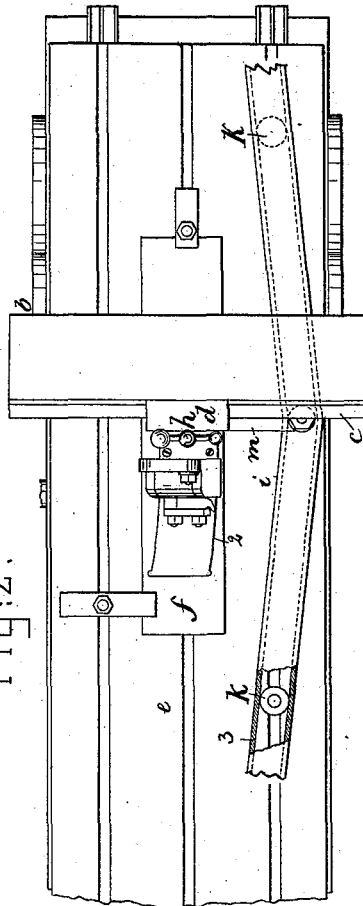

Fig:2.

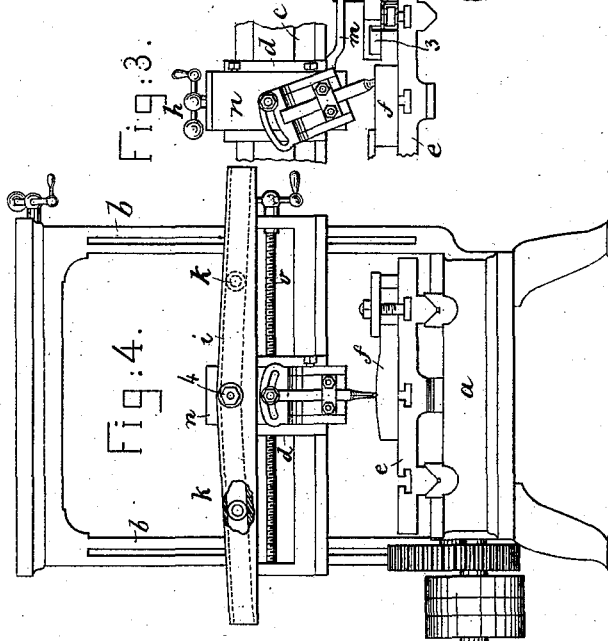

Fig:3.

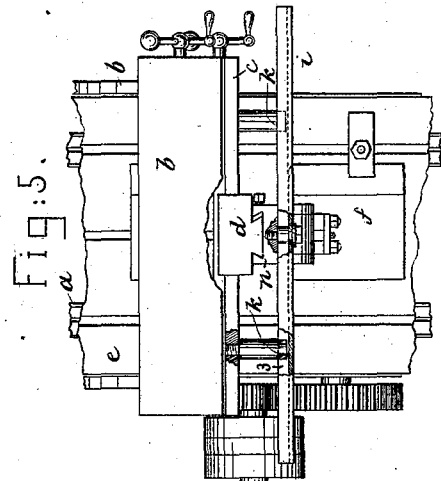

Fig:4.

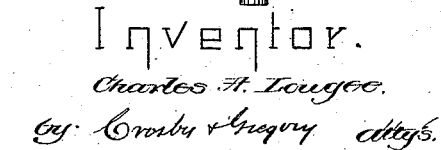

Fig:5.

Witnesses.

Fred A. Powell,
John F. C. Printler,

Inventor.

Charles A. Lougee,
by Crocker & Gregory attys.

UNITED STATES PATENT OFFICE.

CHARLES A. LOUGEE, OF HYDE PARK, MASSACHUSETTS.

AUTOMATIC TOOL-GUIDING DEVICE.

SPECIFICATION forming part of Letters Patent No. 287,828, dated November 6, 1882.

Application filed May 16, 1883. (No model.)

To all whom it may concern:

Be it known that I, CHARLES A. LOUGEE, of Hyde Park, county of Norfolk, State of Massachusetts, have invented an Improvement in Automatic Tool-Guiding Devices, of which the following description, in connection with the accompanying drawings, is a specification, like letters on the drawings representing like parts.

My invention, relating to an automatic tool-guiding device, is shown as applied to a metal-planing machine, and has for its object to enable the tool to be automatically moved, so that it acts in a curved path on the material, which is reciprocated in a rectilinear path upon the lathe-bed.

The tool-controlling apparatus is composed of two members, one of which consists of a guide-piece having guides that are inclined to one another, and co-operate with pins or studs forming the other member of the tool-controlling apparatus. One of the said members is connected with the tool or its holding-clamp, and the other member is connected with some portion of the planer having a movement relative to the tool which is similar to the movement of the material that is being planed.

Figure 1 is a side elevation of a portion of a planer with a tool-controlling apparatus embodying this invention; Fig. 2, a plan view thereof; Fig. 3, a detail showing the tool-controlling mechanism in front elevation; and Figs. 4 and 5, a front elevation and plan view, respectively, of a planer having a tool-controlling device adapted to move the tool in a curved path transversely to the planer-bed.

The frame-work *a*, uprights *b*, cross-slide *c* thereon for the tool-carriage *d*, and the bed or sliding table *e* and means for fastening the material, *f*, thereon, and for reciprocating the said bed, may be of any suitable or usual construction.

As shown in Figs. 1, 2, and 3, the planer is provided with tool-controlling mechanism, by which the tool is moved transversely to the bed upon the cross-slide *c* in a certain definite relation to the longitudinal movement of the bed *e*, or device holding the work to be cut, the resultant of the said movements causing the tool to act upon the material, *f*, being cut in a curved path, as shown at 2, Fig. 2, instead

of in the usual straight path. As shown in this instance, the tool is fed vertically between the successive cuts by the usual feed-screw or vertical tool-feeding mechanism, so that the said tool will gradually cut a portion of a cylindrical surface having its axis vertical or substantially at right angles to the planer-bed.

The tool-controlling mechanism by which the lateral movement of the tool is produced consists of a guide, *i*, having two guideways, (shown as grooves,) *3*, inclined with relation to one another, as best shown in Fig. 2, and adapted to receive studs or rollers *k*, fixed upon the bed *e*, and traveling in unison with the movement of the material, *f*, being planed. The said guide-piece *i* is pivotally connected with a bar, *m*, fastened to the tool-carriage *d*, which latter is disconnected from the usual horizontal feeding mechanism, so as to move freely along the cross-slide *c* under the action of the said bar *m* and guide *i*. The rectilinear movement of the two studs *k* in the inclined guideway of the guide *i* will produce such a movement of the tool-carriage *d* upon the cross-slide that the tool will trace a true arc of a circle upon the bed *e* or material, *f*, carried by it and moving in unison with the said studs.

The radius of curvature may be varied by placing the studs *k* nearer together or more remote from one another. As shown in Figs. 4 and 5, the novel tool-controlling mechanism is arranged to produce a vertical movement of the tool, bearing a definite relation to its horizontal feeding movement transverse to the planer, so that the tool is fed in a curved path transversely to the lathe-bed, and, in connection with the reciprocating movement of the said bed, will enable a cylindrical surface to be cut having its axis parallel with the lathe-bed, instead of at right angles thereto, as in the other application of the invention. In this case the guide *i* is pivotally connected at 4 with the vertically-moving tool-carrying block or holder *n*, and the studs *k* are fixed upon the cross-slide *c*, the usual vertical feed of the block *n* being disconnected, and the carriage *d* being fed transversely by the usual feed-screw, *o*, or other feeding mechanism, for moving the tool transversely to the bed at each reciprocation thereof.

It is obvious that a tool-guiding mechanism

such as described may be applied to other tools than planers—as, for instance, to a lathe when it is desired to turn an object with a convex or concave surface; and other applications will suggest themselves to persons familiar with various metal-working tools.

I claim—

The combination, substantially as shown and described, of a work-holder, a pivoted guide, 10 *i*, having grooves 3, studs *k*, engaging such

grooves, a tool-carriage, *d*, and tool, and a connection for such carriage and the guide, all arranged to operate as set forth.

In testimony whereof I have signed my name to this specification in the presence of two sub- 15 scribing witnesses.

CHARLES A. LOUGEE.

Witnesses:

JOS. P. LIVERMORE,

W. H. SIGSTON.